

# COMPALARM C2C

## ALARM ANNUNCIATOR

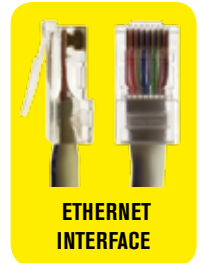

ETHERNET INTERFACE

### GENERAL

The C2C alarm system has been designed to join the maximum possible easiness of operation together with an high level of reliability. Allow the supervision of 12 alarm inputs from configurable contacts (NO,NC). The flush-mount 96x96mm housing combines both the microprocessor logic and alarms display, obtained through LEDs. It is possible to expand with serial and Ethernet communication.

### MAIN FEATURES

- Flush mount housing, 96x96mm
- 12 LED for alarms display
- 3 keys (ACK, RESET, TEST)
- Easy printing alarm legend
- Configuring alarm inputs for use with NO or NC field contacts
- Selectable alarm sequence by dip-switch
- Integral audible alarms
- First-out function
- Two output relays (common and audible)
- Remote keys
- Serial and ethernet communication



### KEYBOARD FUNCTIONS

ACK key-is used to silence the alarm and change the state of the associated alarm LED in accordance with the selected ISA sequence. RESET key-is used to return the alarm to the normal off state once the input has returned to the normal condition. TEST key-is used to test the LED assemblies by illuminating them in a steady state for as long as the pushbutton is pressed.

### DIP-SWITCHES FUNCTIONS

Dip-switch up-is used to configure alarm inputs 1→8 for use with NO or NC field contacts. Dip -switch low (1→4)-is used to configure alarm inputs 9→12 for use with NO or NC field contacts. Dip -switch low (5)-is used to enable internal audible alarms. Dip -switch low (6→8)-is used to select the alarm sequence.

### RELAYS OUTPUTS FUNCTIONS

"R1" output is suitable for alarms cumulative, this output will be activated at normal condition. After an alarm event this contact can be re-enabled only with RESET key, only for sequences that require this key. "R2" output is for audible device. Activates on alarm and remains active until the acknowledge key has been pressed. The contact state of both relays can be programmed to NC or NO using serial or Ethernet communication.

### EXPANSION

The option units are designed and developed to enhance the functions of connectivity. The 485 option implements the isolated RS485 serial interface. The ETH option implements the ETHERNET interface.

### DIMENSIONS

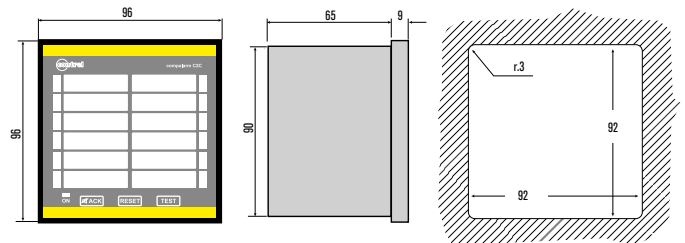

### WIRING DIAGRAM

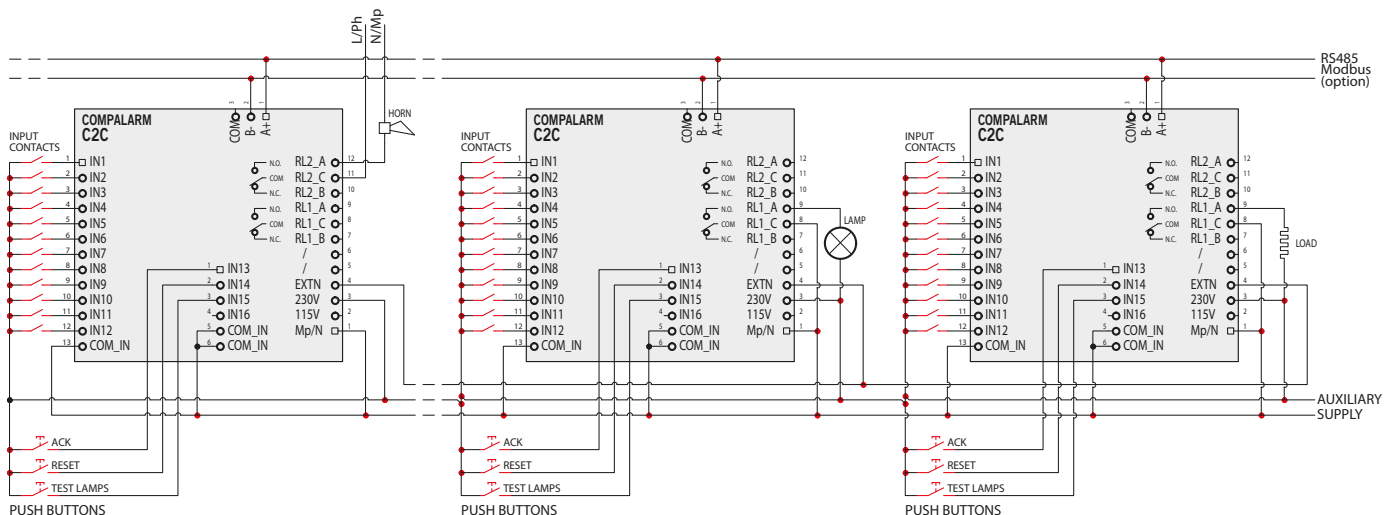

# COMPALARM C2C

ALARM ANNUNCIATOR

TECHNICAL CHARACTERISTICS	C2C
<b>AUXILIARY SUPPLY</b>	
Rated voltage	20...60 Vac/dc - 115/230 Vac - 90...260 Vac/dc
Frequency	50...60Hz
Power consumption	4,5 VA
<b>ALARMS/REMOTE KEYS INPUTS</b>	
Voltage	24 Vac/dc - 48 Vac/dc - 115 Vac/dc - 230 Vac/dc
Current	5 mA max
<b>ALARM INPUTS</b>	
Number of inputs	12
<b>REMOTE KEYS</b>	
Number of remote keys	3 (ACK, RESET, TEST)
<b>OUTPUT RELAYS</b>	
Number of outputs	2 (Alarm cumulative, audible device)
<b>RS485 SERIAL INTERFACE</b>	
Baud-rate	Programmable 9600...38400 bps
Connection	Screw (removable)
<b>ETHERNET INTERFACE</b>	
Network Interface	RJ45 10BASE-T or 100BASETX(auto-sensing)
Compatibility	Ethernet: Version 2.0/IEEE802.3
Protocol	TCP/IP,SMTP,FTP HTTP
Terminal type	RJ45
<b>HOUSING</b>	
Version	Flush mount IEC 61554
Degree of protection	IP40
Weight	500g
<b>AMBIENT CONDITIONS</b>	
Operating temperature	Relative umidity
Storage temperature	-0...+60 °C
Relative umidity	<90%
<b>CERTIFICATIONS AND COMPLIANCE</b>	
Compliant with standards	EN-50081 - EN-50082-2 - EMC89/336/CEE
<b>OPTION</b>	
ORDER CODE	DESCRIPTION
<b>C1</b>	Power supply 20÷60 VAC/DC
<b>C2</b>	Power supply 90÷260 VAC/DC (only for D2 model)
<b>IN24</b>	Voltage inputs 24 VAC/DC
<b>IN48</b>	Voltage inputs 48 VAC/DC
<b>IN115</b>	Voltage inputs 115 VAC/DC
<b>COMMUNICATION</b>	
<b>485</b>	RS485 communication port
<b>ETH</b>	Ethernet interface